

GLASS IS LIFE™

O-I makers of pure, sustainable,
brand-building glass packaging

O-I Sales and Distribution Netherlands B.V.

Postbus 46
3100 AA Schiedam, Netherlands
Tel. +31 (0) 104094444

CONTAINER & MOULD ENGINEERING

EUROPE

NOTES:
THIS DRAWING IS THE PROPERTY OF O-I AND
MUST NOT BE REPRODUCED OR DISCLOSED
WITHOUT O-I WRITTEN AUTHORIZATION.

DIMENSIONS EXPRESSED IN mm
ONLY TOLERANCED DIMENSIONS ARE GUARANTEED.

MANUFACTURING MARKINGS SHOWN ARE FOR ILLUSTRATIVE
PURPOSES ONLY. ACTUAL MARKINGS ON CONTAINER
MAY DIFFER, DÉPENDANT ON LOCAL LEGISLATION.

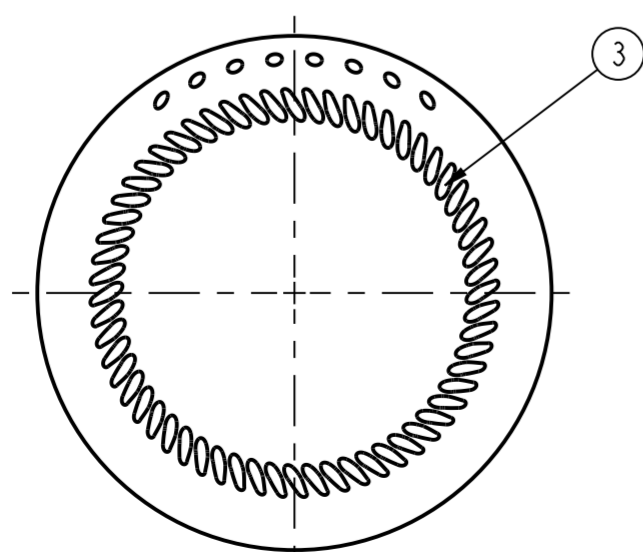
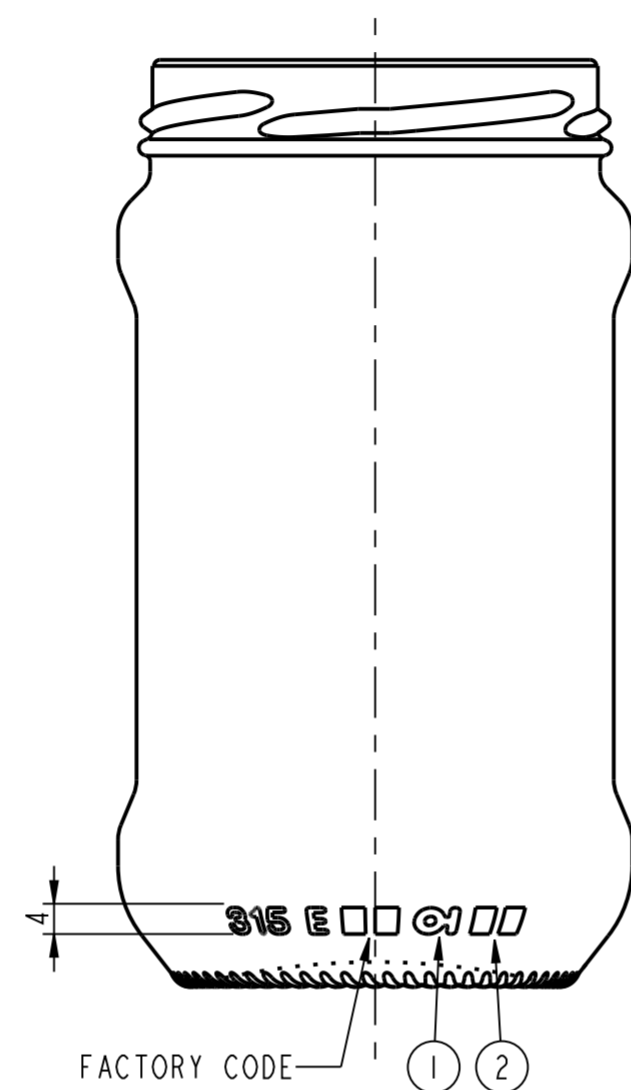
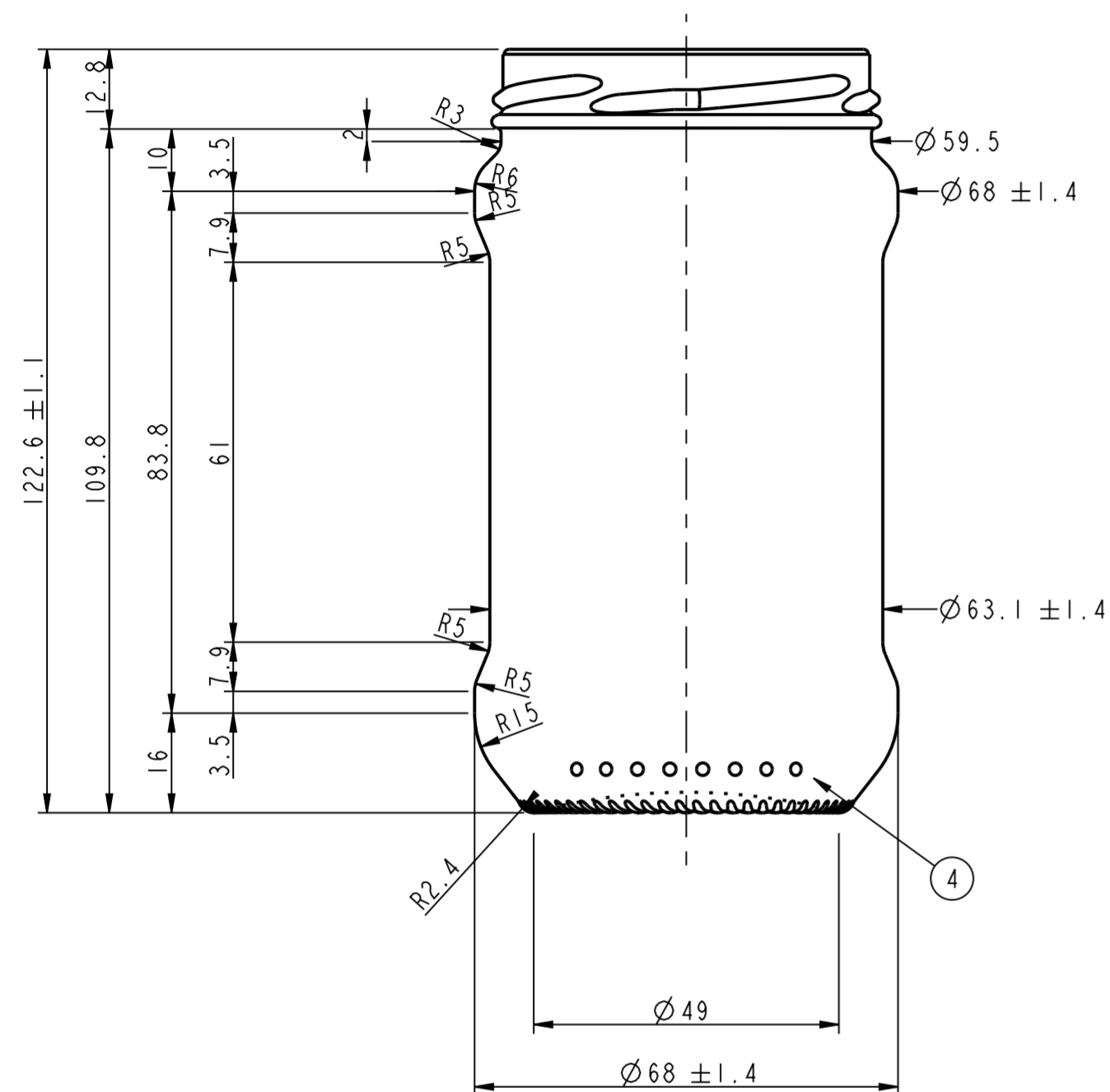

1 = TRADEMARK
2 = CAVITY No.
3 = STIPPLING
THE SHAPE OF STIPPLES IS ONLY AN
INDICATION AND THE CONSTRUCTION IS AT
THE PRODUCTION PLANT DISCRETION.
4 = CAVITY CODE

SCALE 1:1

CATEGORY FOOD	TILT ANGLE 22.62°
	MEASURING CONTAINER YES
FINISH SAP NUMBER 0525	FINISH REF. CETIE GME 20-06 1995
CONTAINER OVERFLOW CAPACITY (BRIMFUL) 315ml ± 10ml	
CONTAINER RATED CAPACITY (FILLPOINT)	
CONTAINER WEIGHT 165g APPROX.	
FINISH DESIGNATION NL_63_GME 20-06_H128_0525	MAX GAS VOLUME
PROCESS P&B	RETURNABLE NO
DESIGN REF.	

Standard Item
315 ml Jar

DESIGNER WD DATE 01/03/16

CHECKED DATE

DRAWING NUMBER 160165 MOULD/SAP NUMBER 003209

No	DATE	REVISIONS	DESIGN/CHECK